

Fire-Rated, Safety-Rated Glass Ceramic
Fire-Rating: 20-180 Minutes

FireLite Plus is a 5/16" (8 mm) thick laminated fire-rated and impact safety-rated glazing material. It is listed for use in doors, sidelites, transoms and borrowed lites.

FEATURES

- ultraHD® Technology for improved surface quality, clarity and color
- Fire-rated for up to 180 minutes with required hose stream test
- Available in two surface grades: Premium and Standard
- Clear and wireless glass ceramic
- Impact safety-rated-meets ANSI Z97.1 and CPSC 16 CFR1201 (Cat. I and II)
- Fits in Fireframes® Designer Series from TGP, or standard fire-rated frames
- Withstands thermal shock
- Large sizes available
- May be lightly sandblasted or etched on one side without affecting fire rating
- Protects from fire and impact on both sides of the glass
- May be insulated (see FireLite IGU fact sheet)
- 5-year limited warranty

Notes: This product is not a barrier to radiant heat, as it does not meet test standards ASTM E119 or UL 263. If your jurisdiction requires a "barrier to heat" product, please contact TGP regarding Pilkington Pyrostop®.

SURFACE GRADES

Standard Grade - Polished for a surface quality that is comparable to alternative fire-rated ceramics marketed as having a premium finish.

Premium Grade - Finish ground and polished on both surfaces to provide superior surface quality, improving overall clarity and providing a surface that is unmatched by alternative products.

LISTINGS/STANDARDS

Classified and labeled by Underwriters Laboratories, Inc.® and Underwriters Laboratories of Canada. File number for labeled fire-rated assemblies is R13377. Tests performed in accordance with:

UL 9	NFPA 80	CAN/ULC-S104	MEA-290-90-M-6
UL 10B	NFPA 252	CAN/ULC-S106	LARR 25798
UL 10C	NFPA 257		



BIM 3D Model Available

ultraHD
TECHNOLOGY



UL Classified & Labeled



Fire-Rated



Hose Stream Tested



Impact-Rated



Positive Pressure Tested

MAXIMUM EXPOSED AREA

RATING	ASSEMBLY	MAX. EXPOSED AREA	MAX. WIDTH OF EXPOSED GLAZING	OR	MAX. HEIGHT OF EXPOSED GLAZING
20 to 60 min.	DOORS (non-temp rise)	3,204 in ² / 22.25 ft ² (2.07 m ²)	36" (914 mm)		89" (2,260 mm)
	DOORS (temp rise)	100 in ² / 0.69 ft ² (.06 m ²)	12" (304 mm)		33" (838 mm)
	OTHER THAN DOORS	3,325 in ² / 23.09 ft ² (2.15 m ²)	95" (2,413 mm)		95" (2,413 mm)
90 min.	DOORS (non-temp rise)	2,034 in ² / 14.13 ft ² (1.31 m ²)	36" (914 mm)		56-1/2" (1,435 mm)
	DOORS (temp rise)	100 in ² / 0.69 ft ² (.06 m ²)	12" (304 mm)		33" (838 mm)
	OTHER THAN DOORS	2,627 in ² / 18.24 ft ² (1.69 m ²)	56-1/2" (1,435 mm)		56-1/2" (1,435 mm)
180 min.	DOORS	100 in ² / 0.69 ft ² (.06 m ²)	12" (304 mm)		33" (838 mm)

Check with frame manufacturer for maximum tested glass sizes and required stop height.

Note: Individual lite sizes cannot exceed "Max. Exposed Area" shown above.

MAXIMUM SHEET SIZE

SURFACE FINISH	Premium	Standard
	48" x 96" (1.21 m x 2.43 m)	48" x 96" (1.21 m x 2.43 m)

GENERAL CHARACTERISTICS

THICKNESS:	Nominal 5/16" (8 mm) overall
WEIGHT:	4 lb / ft ² (19.53 kg / m ²)
APPROX. VISIBLE TRANSMISSION:	85%
APPROX. VISIBLE REFLECTION:	9%
HARDNESS (VICKER'S SCALE):	700
FIRE RATING:	20 minutes to 3 hours
IMPACT SAFETY RATING:	Meets ANSI Z97.1 and CPSC 16FR1201 (Cat. I and II)
STC RATING:	38

LABELING

Each piece of FireLite Plus shall be permanently labeled with the FireLite Plus logo, UL logo and fire rating.

Detail based on use of Fireframes Designer Series narrow profile framing

Glazing Thickness: 5/16" – 1"
(8 mm – 25.4 mm)

- a. Frame width: 2" (51 mm)
- b. Frame height: 2-3/4" (70 mm)
- c. Stop height: 3/4" (19 mm)
- d. Pocket width: 1/2" – 1-1/4"
(12.7 mm x 31.8 mm)
- e. Edge clearance: 1/4" (6.4 mm)
- f. Bite: 1/2" (12.7 mm)

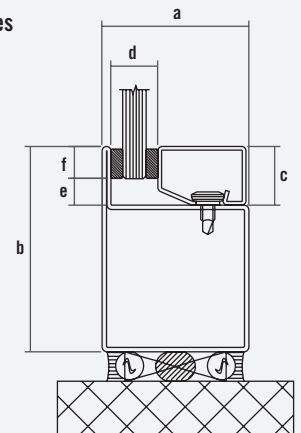

INSTALLATION

FireLite Plus shall be glazed into the appropriate fire-rated framing with an approved glazing compound (closed cell PVC tape or DAP 33 putty) as supplied by the installer. For 90 minute ratings that exceed 1,393 in² (.8987 m²), FireLite Plus shall be glazed with fire-rated glazing tape as supplied by TGP.

Inspect each piece of FireLite Plus immediately before installation and eliminate any with observable edge damage or face imperfections. As with any glass produced by the “roll out” method, individual pieces of FireLite Plus may contain minimal variations in thickness. Occasionally, process marks and small occlusions or seeds (bubbles, knots or crystals) may be apparent. However, since they do not generally impair the transparency or affect the technical performance of the glass, they do not represent cause for rejection.

STORAGE & HANDLING

FireLite Plus must be handled with care during transportation, storage, inspection and installation. Store in a dry place.

FAMILY OF PRODUCTS

TGP offers a complete family of products for all your fire-rated glazing needs, ranging from 20 minute to 3 hour applications. More information is available online at fireglass.com, or by calling 800.426.0279.

Fireglass®20

Fire-rated, impact safety-rated glass

FireLite®

Fire-rated glass ceramic

FireLite® NT

Fire-rated, impact safety-rated glass ceramic with surface-applied film

FireLite Plus®

Fire-rated, impact safety-rated glass ceramic

FireLite® IGU

Fire-rated or fire/impact safety-rated insulated glass units

Pilkington Pyrostop®

Fire-rated, impact safety-rated transparent wall panels

WireLite®

Fire-rated, wired glass

WireLite® NT

Fire-rated, impact safety-rated wired glass with surface-applied film

Fireframes®

Fire-rated framing & doors for use with all TGP glass products